

Health Parameters Monitoring System

Dr. Tushar Patil, Mr. Dhanesh Patil, Dr. Yogita Patil, Mr. Deepak Khadse

Mr. Prashant Chaudhari

G H Raisoni College of Engineering & Management, Jalgaon, Maharashtra India-425002

Abstract: In today's society, there are an increasing number of people whose health need regular health examinations. The other category consists of people who have died or are suffering from specific diseases, the consequences of which can occur unexpectedly and result in a grave health crisis. The idea is to provide constant remote monitoring of particular patient functions that are critical to their survival, as well as the necessary assistance. The sensing of essential data related to a person's health wherever they are can be transmitted into a technical centre where it will be reviewed and understood under remote monitoring. This concept's applicability has a lot of potential. This work considers non-invasive sensors for monitoring of some physiologic parameters, data transit and processing, archiving, and visualization in addition to the aforementioned groups. This methodology served as the foundation for subsequent applied research projects established in collaboration with hospitals.

Keywords: Remote monitoring, Zigbee technology, TELEKARD System, Microcontroller

1. Introduction

For testing of physical exercise, we require the interaction of physiologic mechanisms that enable the circulatory and respiratory systems to handle the increased energy demands of contracting muscles. As a result, during actual working; systems get strained. Physical competence (or "health") is a measure of their capacity to respond appropriately to this stress. Understanding the normal response profiles of the gas transport systems that maintain cell respiration is required to recognize the abnormal response patterns that characterize the many disease states that affect them. Exercise necessitates an increase in O₂ in the muscles due to the higher metabolic rate. CO₂ produced by muscles must be expelled to avoid severe tissue acidosis and its consequences for cellular function. All of the organs involved are the lungs, heart, pulmonary circulation and peripheral circulation. Lung ventilation, Heart rate and breathing frequency are all measured non-invasively in the patient's breath. The computer calculates the standard settings using these data. An important component of the development of such systems are embedded measurement and management systems, which are implanted directly on the patient body and feel the necessary patient data. When using measurement and control systems in medical systems for medical diagnostics, we always run into signal processing difficulties.

Patient body temperature monitoring is done using Zigbee by [1]. Patient body temperature monitoring using a low-cost wireless system using an 8-bit RISC microcontroller and a ZigBee transmitter is done by [2]. Based on android platform patient monitoring system is developed which is able to detect various body parameters like temperature, pulse rate and heartbeat by [3]. A Review of Remote Patient Monitoring System is done by [4]. Health monitoring device is design and implemented with the help of FPGA in [5]. Patient Bed-Side Monitoring Desk which is Android-based is developed by [6]. Remote patient monitoring systems is reviewed in [7], Blood and Heart related systems, brain and nervous system related systems, mental health and diabetics research have also been discussed. The smart healthcare system is introduced by [8] to monitor the patient body temperature, heart rate as well as various indicators of the state of a hospital room, such as room humidity, CO levels and CO₂ gas levels.

2. Implementation

For data measurement, two systems have been created:

a) A KARD system is used for exercise testing inside laboratory.

b) A TELEKARD is a portable telemetric exercise testing system which may be used in the lab or in the field to assess cardio respiratory function for e.g. rehabilitation and sports medicine.

KONSIL is a program that was built to evaluate data. Both systems use the same program.

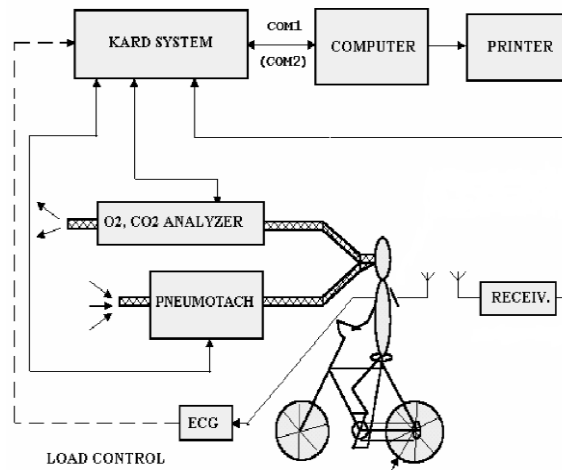

Figure 1: Stress Testing Apparatus in the Laboratory

The microcontroller-based KARD system is used for laboratory testing. The AVR Atmel16 microcontroller is used in this system. If necessary, an ECG can be linked to measure heart rate. The KARD system was developed to work with a variety of vintage gas analyzers (Spirally or inferably), but it can also work with new gas analyzers. The ventilation was measured using a gas meter with a digital serial output. The SPORTTESTER heart rate meter is used to measure and transmit heart rate information.

The TELEKARD system is depicted in block diagram form in Figure 2. This is a device that is “wireless” (telemetric system). The device is made up of a unit (carried by the item) that sends measured data to a receiver in time.

TELEKARD system uses a receiver attached to a personal computer (PC) that displays information on the following devices: -

- a) Expiratory- Oxygen sensor with a range of 0 - 100 percent.
- b) Percentage of CO2 Expiratory Infrared carbon dioxide sensor is 0-10%
- b) Heart rate meter- SPORTMETER or Heart rate sensor is used to measure heart pulse.
- d) Turbine flow meter with a diameter of 26mm and a VE range of 10-250 l/min.
- e) Pressure Sensor: The MPX5010 is a Signal conditioned, temperature compensated, and calibrated differential dual ports integrated silicon pressure sensor on chip
- f) For temperature measurement, the LM 35 can be utilized as a temperature sensor.

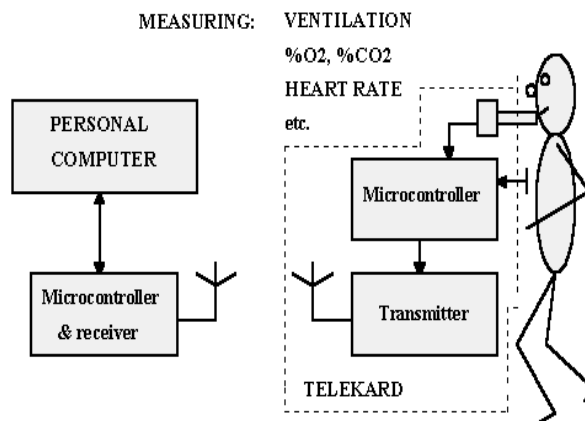

Figure 2: The TELEKARD System

In the TELEKARD system all signals are passed to the microcontroller (AVR Atmel16), after that passed to RF module Tarang F4 Zigbee and user can able to see it on Personal Computer at receiver side as shown in figure 2.

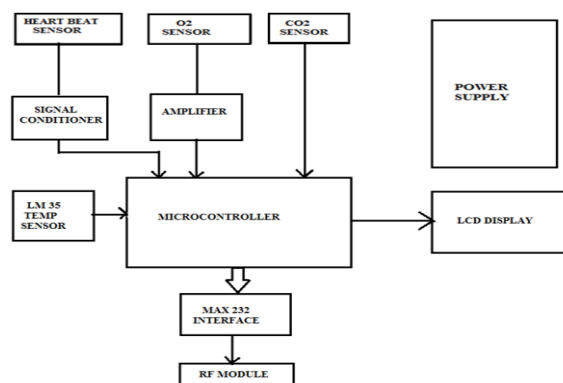

Figure 3: TELEKARD System Block Diagram

A) HEART RATE SENSOR:

The heart beat sensor produces a digital output of the heart pulse, when a finger is placed on it. With each heartbeat, the beat LED glows in unison when the heart beat detector works. This digital output can be directly connected to the microcontroller for measurement the BPM (Beats Per Minute) rate. It works on the principle of light modulation by blood flow via the finger at each pulse.

B) AVR MICROCONTROLLER:

It is an AVR 16-bit microcontroller with outstanding performance and low power consumption. It has non-volatile data and program memory. It features 135 instructions, most of which only require a single clock to execute; hence data execution takes far less time than on other microcontrollers.

C) Serial Communications- RF Module Operation:

The OEM RF modules for Xbee/Xbee-PRO connect to the host device through a logic-level asynchronous serial connection. The module can connect with any logic and voltage compatible UART via its serial port, or with any serial device via a level translator (for example, via an RS-232 or USB interface board) [9].

D) FLOW of DATA FROM THE UART

Those devices which have an interface to UART will connect to the RF module as shown in figure 4.

E) SERIAL COMMUNICATION of DATA:

The UART module receives data as an asynchronous serial signal through the DI pin (pin-3). When there is no data transmission then, signal should be high. Data byte consist of a start bit(Low), eight data bits and stop bit(High). Pattern of the data travelling by way of the module is as shown in figure 5.

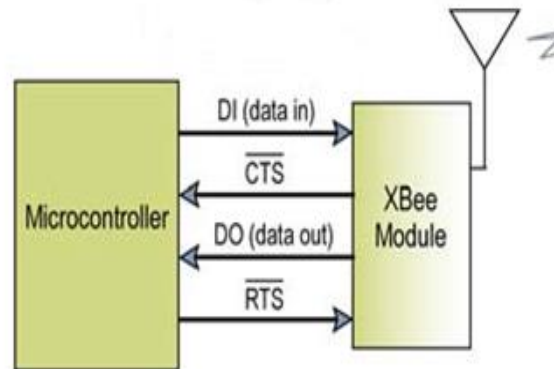

Figure 4: The Data Flow of a System in a UART-Interfaced Environment

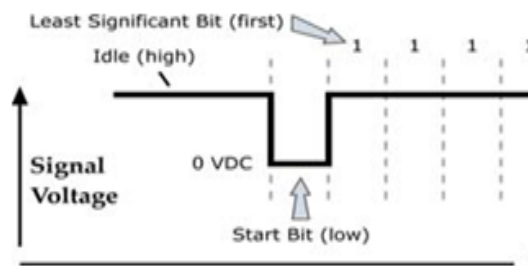

Figure 5: RF-Module Data Packets as Transmitted via UART

A parity bit is used to indicate the change in data during transmission. If the parity bit does not match with the data, then universal asynchronous receiver/transmitter (UART) identifies an error in the data frame. Two UARTs must be configured with suitable settings for serial communication to work (data bits, baud rates, parity, stop bit and start bit).

3. Result And Observation

This project's design is split into two halves. The AVR microcontroller is used to implement the software on the transmitter side. At the transmitter side, the software is implemented on an AVR microcontroller using AVR Studio. The entire transmitter code is written in assembly language. Hyper terminal is used to implement software on the receiver's side. Figure 6 depicts the measured data from one volunteer, where O2 is the blood oxygenation index, PPM is the heart rate, and TEMP is the body temperature. Within 75 seconds, the data will be displayed on the LCD screen. The blood oxygenation (O2) level is 26 percent and remains steady throughout time. The heart rate signal ranged between 72 and 90 beats per minute (beats per minutes), which is to be expected for an older man. It also reveals that the measured body temperature was around 34.1C, and that it took around 30 seconds for the temperature to stabilise at that level.

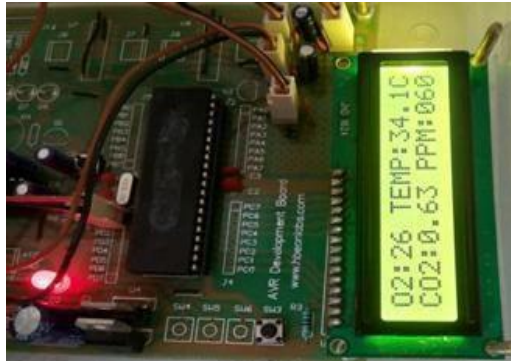

Figure 6: Result and Readings at Transmitter Side

In an open space, the greatest error-free distance for wireless transmission is roughly 15 metres. It's lengthy enough for practical use in the patient's personal area. Display of a correctly transmitted monitored signal is as shown in Figure 7.

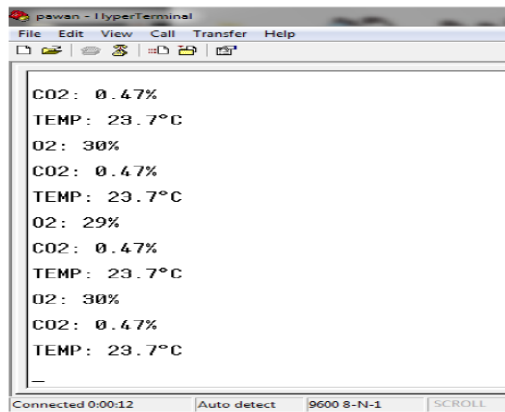

Figure 7: Signals of Respiration and Temperature at the Receiver

Overall built biomedical system with all noninvasive sensors and essential hardware for determining physiologic parameters is as shown in figure 8.

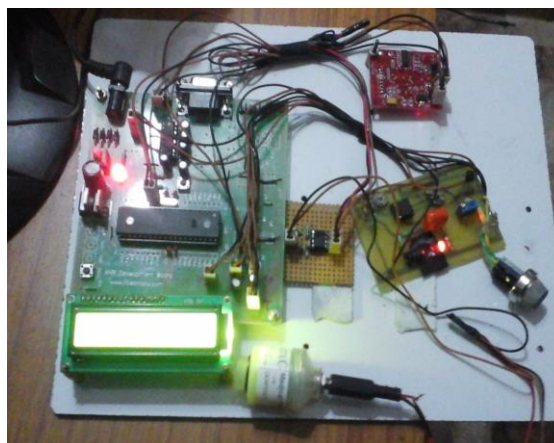

Figure 8: Developed Biomedical System

3.3 List of Calculated data:

During the exercise testing Temperature, heart rate, percent O₂ Expiratory, and percent CO₂ Expiratory information is gathered by the TELEKARD. The measured values are calculated from these signals.

4. CONCLUSION

Physiologic data acquired during physical workouts was used to showcase the embedded system. Using all relevant sensors, a correctly given workout test is performed. This enables objective and evaluation of the patient's performance, reserves, and limits, which is required to make a correct differential diagnosis and prescribe suitable treatment. Automatic stress testing programs and systems were created in collaboration with doctors.

References

- [1] Jetsada Arnil, Yunyong Punsawat, and Yodchanan Wongsawat, "Wireless Sensor Network-based Smart Room System for Healthcare Monitoring", Proceedings of the 2011 IEEE International Conference on Robotics and Biometrics December 7-11, 2011, Phuket, Thailand, pp.2073-2076.
- [2] Ankita Gupta, Sharmelee Thangjam, "AVR Based Temperature Monitoring and Controlling Using ZigBee in Matlab" International Journal of Engineering Research & Technology (IJERT), ISSN: 2278- 0181, Vol. 1 Issue 3, May – 2012, pp 01-04.
- [3] Deep Modi, Jignesh Vyas, Priyank Shah, "Android Based Patient Monitoring System" ISSN (Online): 2347 – 4718, International Journal For Technological Research In Engineering Volume 1, Issue 9, May-2014.
- [4] Amol Wanjari , Madan Mali, "A Review: Remote Patient Monitoring System", International Journal of Advanced Research in Computer and Communication Engineering (IJARCCE) Vol. 5, Issue 5, May 2016, pp.544-547.
- [5] Vaibhavi Bhelkar, D. K. Shedge, " Design and Implementation of Health Monitoring Device using FPGA", International Journal of Computer Applications (0975 – 8887) Volume 158 – No 7, January 2017, pp.8-11.
- [6] Salman ul Mouzam, Muhammad Daud, Salman Ali, Abdul Qadir Ansari, "Design of Android-Based Remote Patient Monitoring System", International Journal of Advanced Computer Science and Applications, (IJACSA) , Vol. 9, No. 6, 2018, pp.189-192.
- [7] Lakmini P. Malasinghe, Naeem Ramzan, Keshav Dahal, "Remote patient monitoring: a comprehensive study", Springer, J Ambient Intell Human Comput , 2019, DOI 10.1007/s12652-017-0598-x, pp.57–76.
- [8] Md. Milon Islam, Ashikur Rahaman, Md. Rashedul Islam, "Development of Smart Healthcare Monitoring System in IoT Environment", SN Computer Science (2020) 1:185 <https://doi.org/10.1007/s42979-020-00195-y> pp. 1-11.
- [9] XgbeePRO-RF-Module <http://www.digi.com/products/wireless-wired-embeddedsolutions/zigbee-rfmodules/point-multipoint-rfmodules/xbee-series1-module#overview>.
- [10] Heart rate Sensor Available: <http://pulsesensor.com/category/the-long-blurb/diy-monitors-the-long-blurb>.
- [11] Microcontroller <http://www.engineersgarage.com/sites/default/files/Amega16.pdf>.
- [12] Patil, T. M., & Bhadade, U. S. (2017). Analysis of Modified Load Coil for IH Geysers, IEEE TENSYP 2017, IEEE Region 10 Symposium, Le-meridian, Cochin, India, 14–16 July 2017.